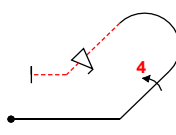
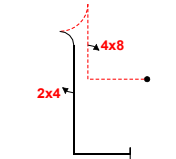
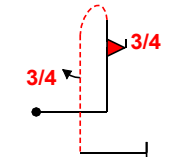
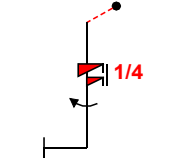
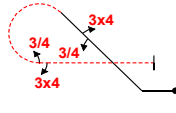
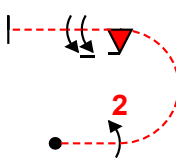
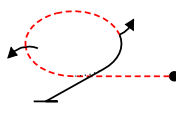
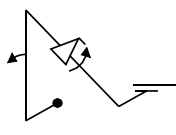

Pilot ID

France Doret/excellence connu

Flight #

No	Symbol	Cat. No.	K	Total K	Grade	Pos	Remarks	Item	K	Grade
1		8.4.13.1 9.4.2.4 9.9.9.4	11 13 13	37	.			Pos.	35	
								Harm.	0	
2		6.2.2.4 9.8.1.2 9.4.5.2	17 11 5	33	.			Fig K	Total K	
								345	380	
Penalties										
3		8.4.3.1 9.10.6.3 9.1.5.3	15 19 6	40	.			Too Low		
								Too High		
								Interruptions		
								Insertions		
								Trg Violation		
								Wing Rocks		
								Disqual Fig		
Other(note...)										
Final Freestyle										
5		1.1.7.4 9.12.1.5 9.1.5.4	9 6 8	23	.			Duration	Min	Sec
Judges Details										
6		8.5.1.1 9.1.2.3 9.4.2.3 9.1.3.3 9.4.3.3	12 8 10 6 8	44	.			Signature		
								Name		
								Number		
7		7.2.2.2 9.2.3.4 9.10.3.2 9.1.3.8	9 9 13 12	43	.					
8		2.3.2.4	37	37	.					
9		1.2.6.1 9.1.1.2 9.9.4.4 9.1.4.4	14 8 11 8	41	.					

Pilot

A/C

Pilot ID

France Doret/excellence connu

Flight #

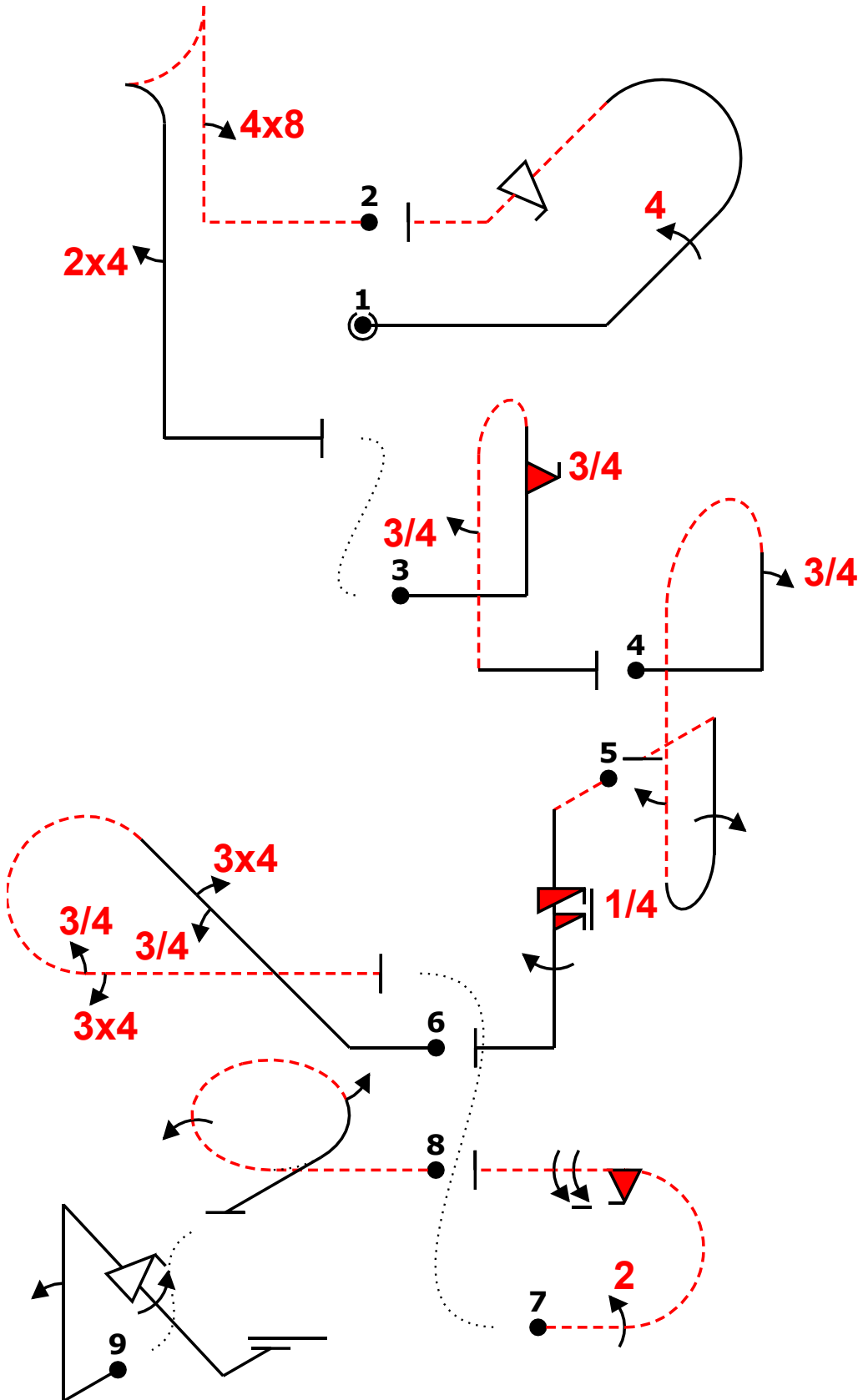
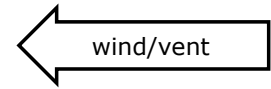

Power			
Fig	Aresti	K	
1	8.4.13.1	11	37
	9.4.2.4	13	
	9.9.9.4	13	
2	6.2.2.4	17	33
	9.8.1.2	11	
	9.4.5.2	5	
3	8.4.3.1	15	40
	9.10.6.3	19	
	9.1.5.3	6	
4	8.8.5.1	21	47
	9.1.1.3	10	
	9.1.5.2	4	
	9.1.1.4	12	
5	1.1.7.4	9	23
	9.12.1.5	6	
	9.1.5.4	8	
6	8.5.1.1	12	44
	9.1.2.3	8	
	9.4.2.3	10	
	9.1.3.3	6	
	9.4.3.3	8	
7	7.2.2.2	9	43
	9.2.3.4	9	
	9.10.3.2	13	
	9.1.3.8	12	
8	2.3.2.4	37	37
9	1.2.6.1	14	41
	9.1.1.2	8	
	9.9.4.4	11	
	9.1.4.4	8	
Total K = 345 (max K = 350)			

Pilot
A/C

CONNU 01 2020		Form C
Pilot ID	France Doret/excellence connu	Flight #

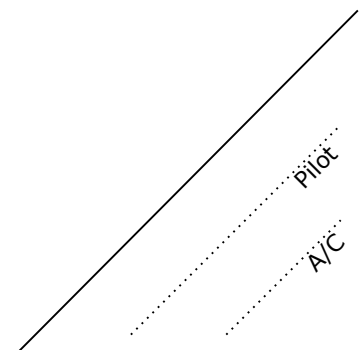
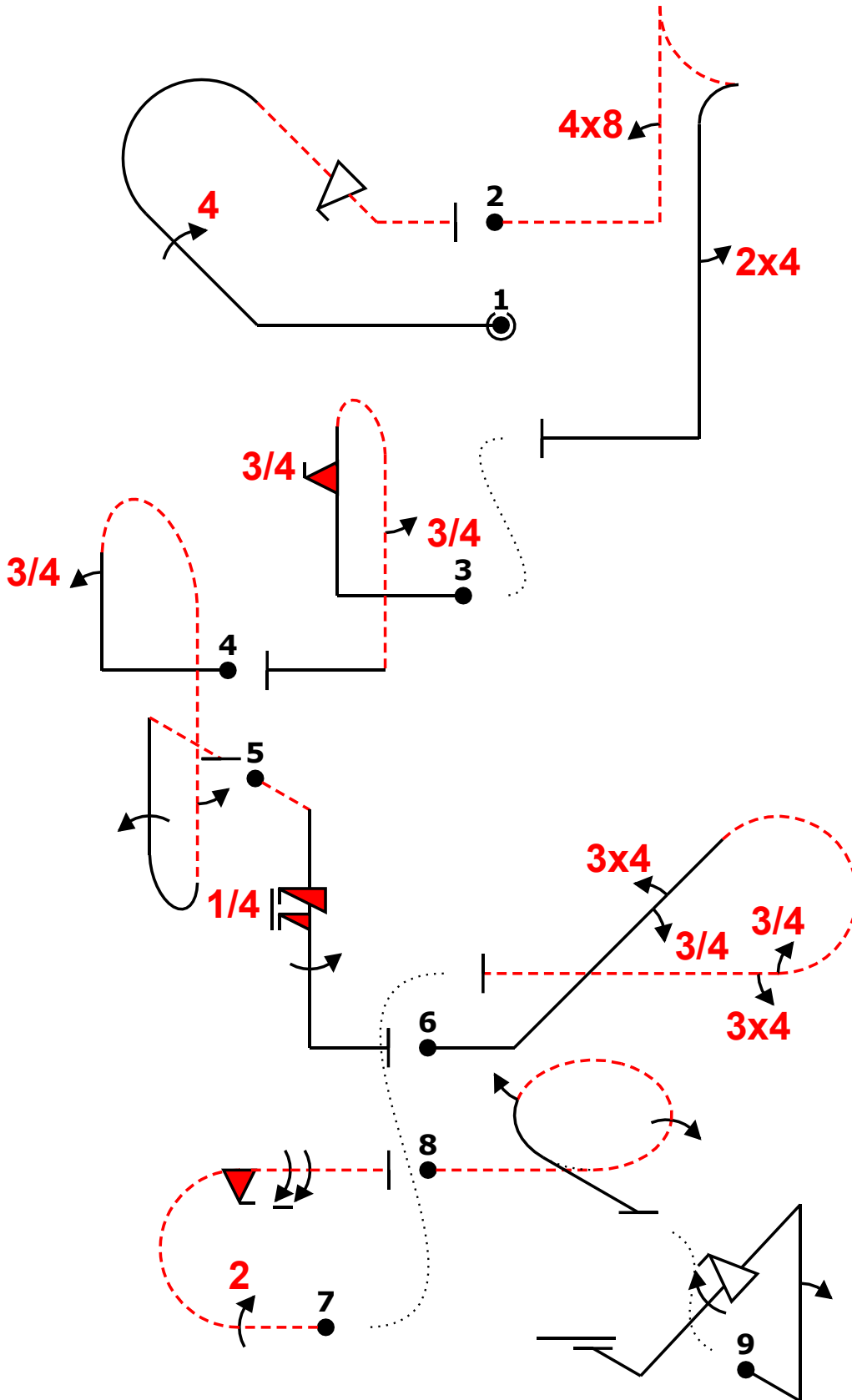
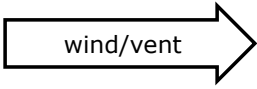

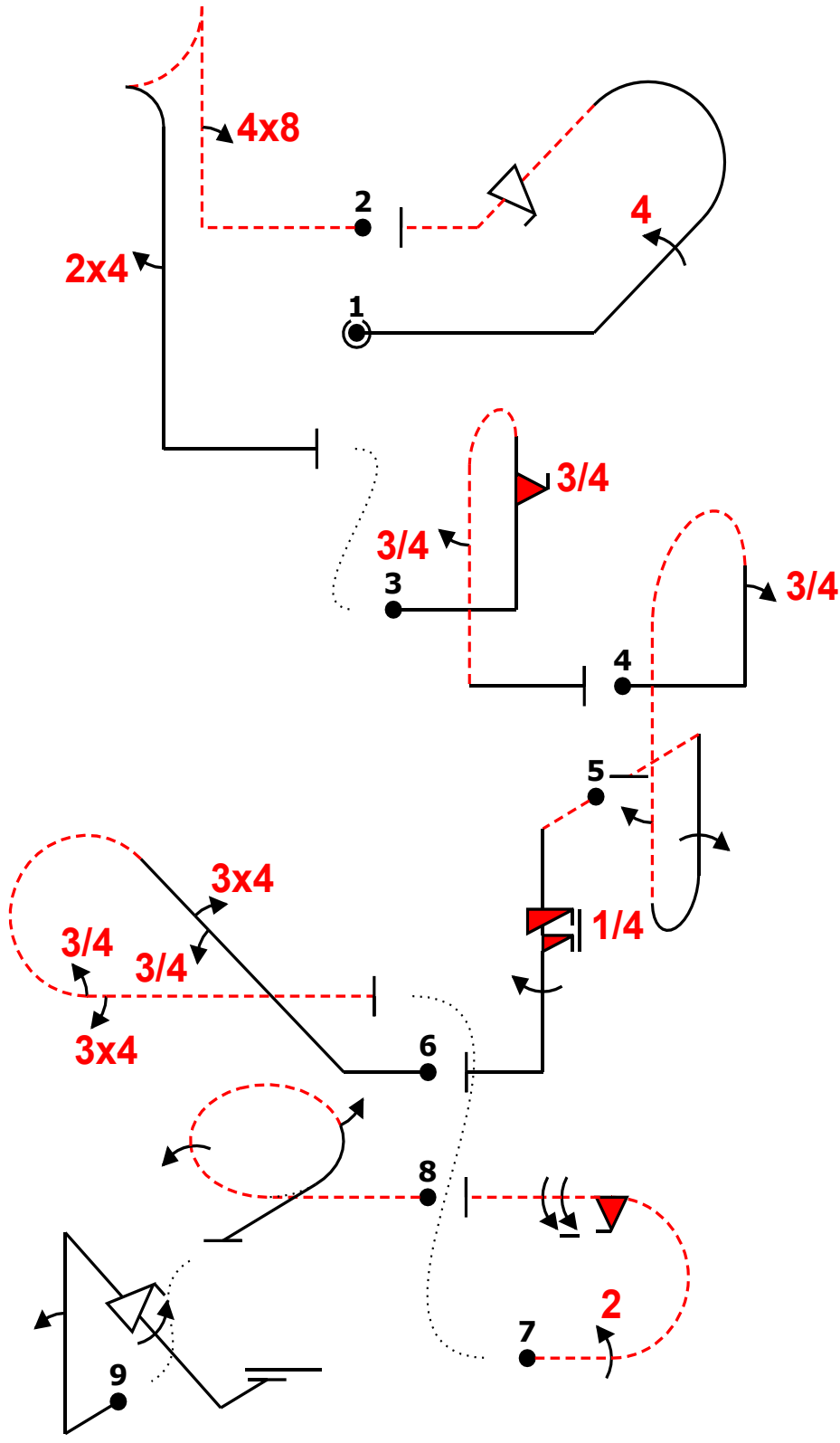

44dbf- --,48ita',24...' (0,8) ,3ifpb'',3.> ,3pBb(,2),1'- -iv5is,1 3,34rc3,34- (4,18) -22m2if;9- -3jo15 (-2,6) 2kf ;1

Fig	Grade	Pos	Remarks
1	.		
2	.		
3	.		
4	.		
5	.		
6	.		
7	.		
8	.		
9	.		

Positioning	35	.
-------------	-----------	---

Too Low		Trg Violation	
Too High		Wing Rocks	
Interruptions		Disqual Fig	
Insertions		Other(note...)	

Fig 1	K	Fig 2	K	Fig 3	K	Fig 4	K	Fig 5	K	Fig 6	K	Fig 7	K	Fig 8	K	Fig 9	K
8.4.13.1	11	6.2.2.4	17	8.4.3.1	15	8.8.5.1	21	1.1.7.4	9	8.5.1.1	12	7.2.2.2	9	2.3.2.4	37	1.2.6.1	14
9.4.2.4	13	9.8.1.2	11	9.10.6.3	19	9.1.1.3	10	9.12.1.5	6	9.1.2.3	8	9.2.3.4	9			9.1.1.2	8
9.9.9.4	13	9.4.5.2	5	9.1.5.3	6	9.1.5.2	4	9.1.5.4	8	9.4.2.3	10	9.10.3.2	13			9.9.4.4	11
						9.1.1.4	12			9.1.3.3	6	9.1.3.8	12			9.1.4.4	8
										9.4.3.3	8						
SF 4	37	SF 6	33	SF 4	40	SF 7	47	SF 3	23	SF 7	44	SF 4	43	SF 2	37	SF 4	41

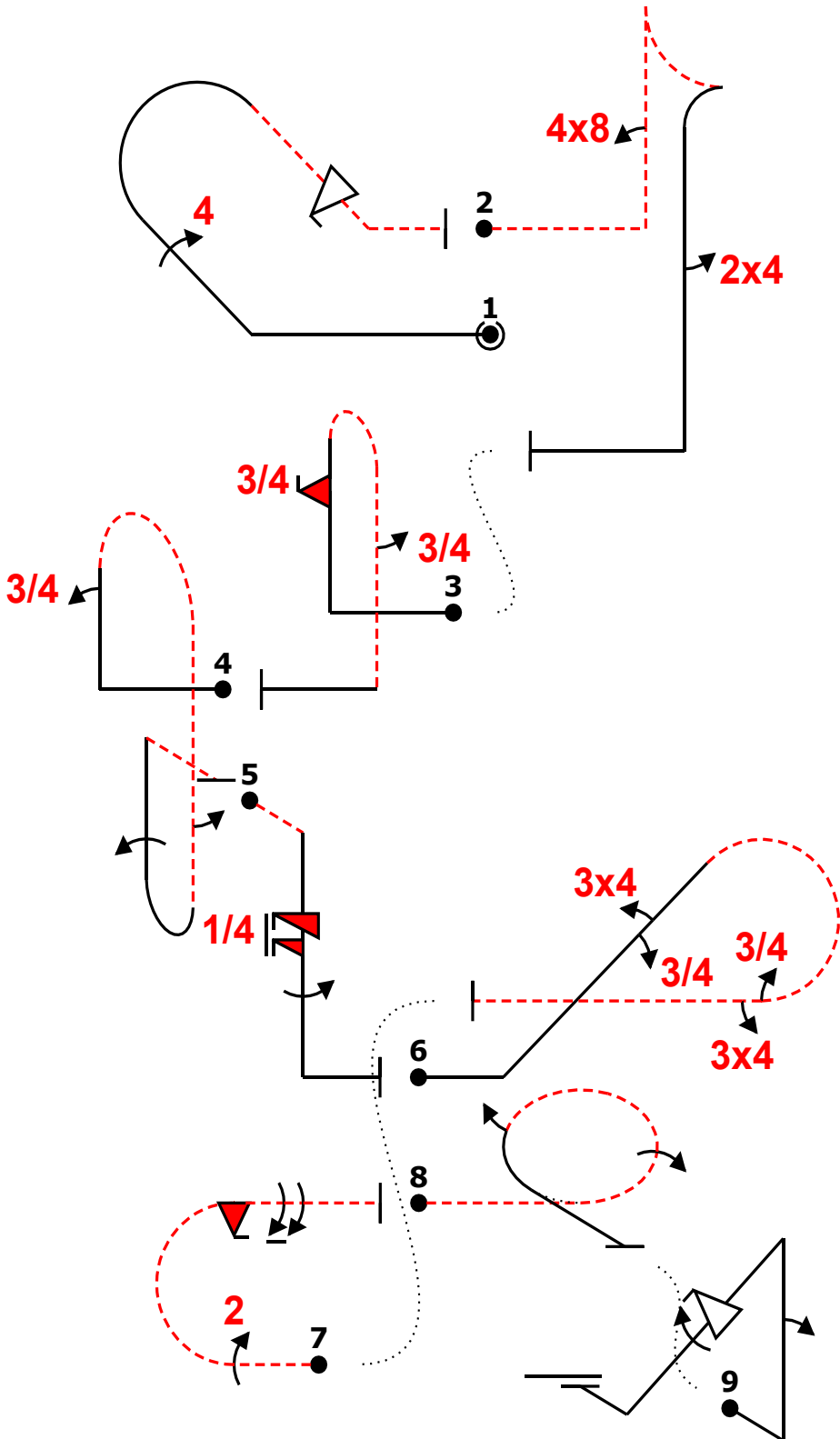
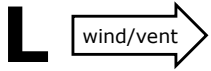

Fig	Grade	Pos	Remarks
1	.		
2	.		
3	.		
4	.		
5	.		
6	.		
7	.		
8	.		
9	.		

Positioning	35	.
-------------	----	---

Too Low		Trg Violation	
Too High		Wing Rocks	
Interruptions		Disqual Fig	
Insertions		Other(note...)	

44dbf- --,48ita',24..' (0,8) ,3ifpb'',3.> ,3pBb(,2),1'- -iv5is,1 3,34rc3,34- (4,18) -22m2if;9- -3jo15 (-2,6) 2kf ;1

Fig 1	K	Fig 2	K	Fig 3	K	Fig 4	K	Fig 5	K	Fig 6	K	Fig 7	K	Fig 8	K	Fig 9	K
8.4.13.1	11	6.2.2.4	17	8.4.3.1	15	8.8.5.1	21	1.1.7.4	9	8.5.1.1	12	7.2.2.2	9	2.3.2.4	37	1.2.6.1	14
9.4.2.4	13	9.8.1.2	11	9.10.6.3	19	9.1.1.3	10	9.12.1.5	6	9.1.2.3	8	9.2.3.4	9			9.1.1.2	8
9.9.9.4	13	9.4.5.2	5	9.1.5.3	6	9.1.5.2	4	9.1.5.4	8	9.4.2.3	10	9.10.3.2	13			9.9.4.4	11
						9.1.1.4	12			9.1.3.3	6	9.1.3.8	12			9.1.4.4	8
										9.4.3.3	8						
SF 4	37	SF 6	33	SF 4	40	SF 7	47	SF 3	23	SF 7	44	SF 4	43	SF 2	37	SF 4	41

wind/vent ←

